



by Johnson Safety Inc.

<http://www.myronanddavis.com>

Installation Instructions

Volkswagen Series

NV7VWU1



INSTALLATION INSTRUCTIONS AND USE

The Myron & Davis In-Dash Navigation System Includes a built in DVD player that should not be viewed by the driver while driving to avoid violation of State and Local Laws. This product should be installed by a professional to ensure proper installation and operation.

Myron & Davis is not responsible for any potential accidents, property damage or bodily harm that might result from improper installation or operation.

myron&davis

- Read the entire installation instructions prior to performing any work.
- Before installation, check to see that all parts are not damaged or defective.

1 - Ensure all appropriate materials are available

These are some of the common installation items you will need:

- Digital Multi – Meter
- Philips screwdriver set
- Trim Removing tools
- ¼" drive sockets
- Torx or Allen-drive wrenches
- A functional DVD or CD

Installation Guide

2- Caution

-Battery

Check the battery to ensure it's fully charged

NOTE: Some new vehicles batteries are not fully charged and may cause improper operation

3 - Warning

- Remove the key from the ignition
- Disconnect the negative battery terminal
- Care must be used working with vehicles with airbags to prevent:
 - injury
 - damage to or malfunction of the airbag system
 - work on malfunctioning systems or components must be performed by certified technicians

4 - Removing the Dash Trim

Use caution when removing dash trim components as not to damage or mar the surfaces or damage the fasteners

- **Inspect all fasteners for damage and replace as necessary.**

4 – Removal of the Dash Trim Cont'd.

Step 1. Loosen defrost grill



Step 1a. Remove defrost vent grill



Step 1b. Remove vent adjuster screw



Step 1c. Remove vent adjuster



Step 1d. Remove screws securing A/C vents



Step 1e. Loosen A/C vents



Step 1f. Push vents up



5 – Remove Factory Radio

Remove the OEM Radio and prepare the Myron and Davis Unit for installation by following the steps below.

Note: Inspect all fasteners and brackets for damage. Replace as necessary before the installation process is started

Step 1. Loosen 4 screws securing factory radio



Step 1a. Remove factory radio and disconnect .



6 - GPS Antenna, Optional Satellite Radio, and iPod interface

The GPS and Optional Satellite Radio Antenna should be mounted on the exterior of the vehicle and optional iPod interface connector in a user friendly location within the vehicle cabin. Follow the steps below for proper installation.

Note: Avoid routing the GPS harness near other power sources to ensure peak operation

Step 1. Mount GPS and Satellite radio antenna



Step 1a. Connect satellite radio



Step 1b. Mount satellite radio and iPod module



Step 4 - Position the iPod interface connector conveniently for end user use.



Caution: It is the responsibility of the installer to ensure that the vehicle safety equipment is not compromised or adversely affected by the installation of the system. Route the harnesses so as not to obstruct air bags, SRS or other safety devices

7 - Connect and install the Myron & Davis unit

Follow the steps below to ensure proper installation and connection of the Myron and Davis unit.

Note: To ensure that the video cannot be viewed while the vehicle is in motion, connect the (blue/white) Brake Wire to the Emergency Brake Switch
(grounded when engaged)

Note: Carefully route the wire harnesses so they cannot be damaged during the installation process of the Myron and Davis unit

Step 1. Remove transportation screws

Step 1a. Connect Myron and Davis unit

Step 1b. Connect antenna

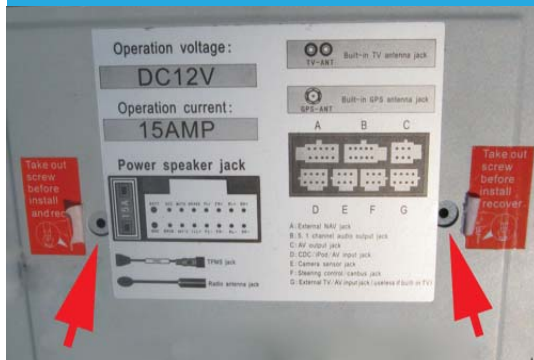

***Note:** The reverse wire and illumination wire are built into the harness and work off of the CAN Bus.

You will be required to re-install the interior trim components in reverse order of removal after installing the Myron and Davis unit. Please refer to the removal steps in Section 4.

Caution: During the installation of the interior trim components, use caution to prevent damage to any of it's components. Consult the Factory Service Manual for any additional instructions.

Caution: After installation of the trim components inspect them to insure they are secure.

Step 1. Final installation view



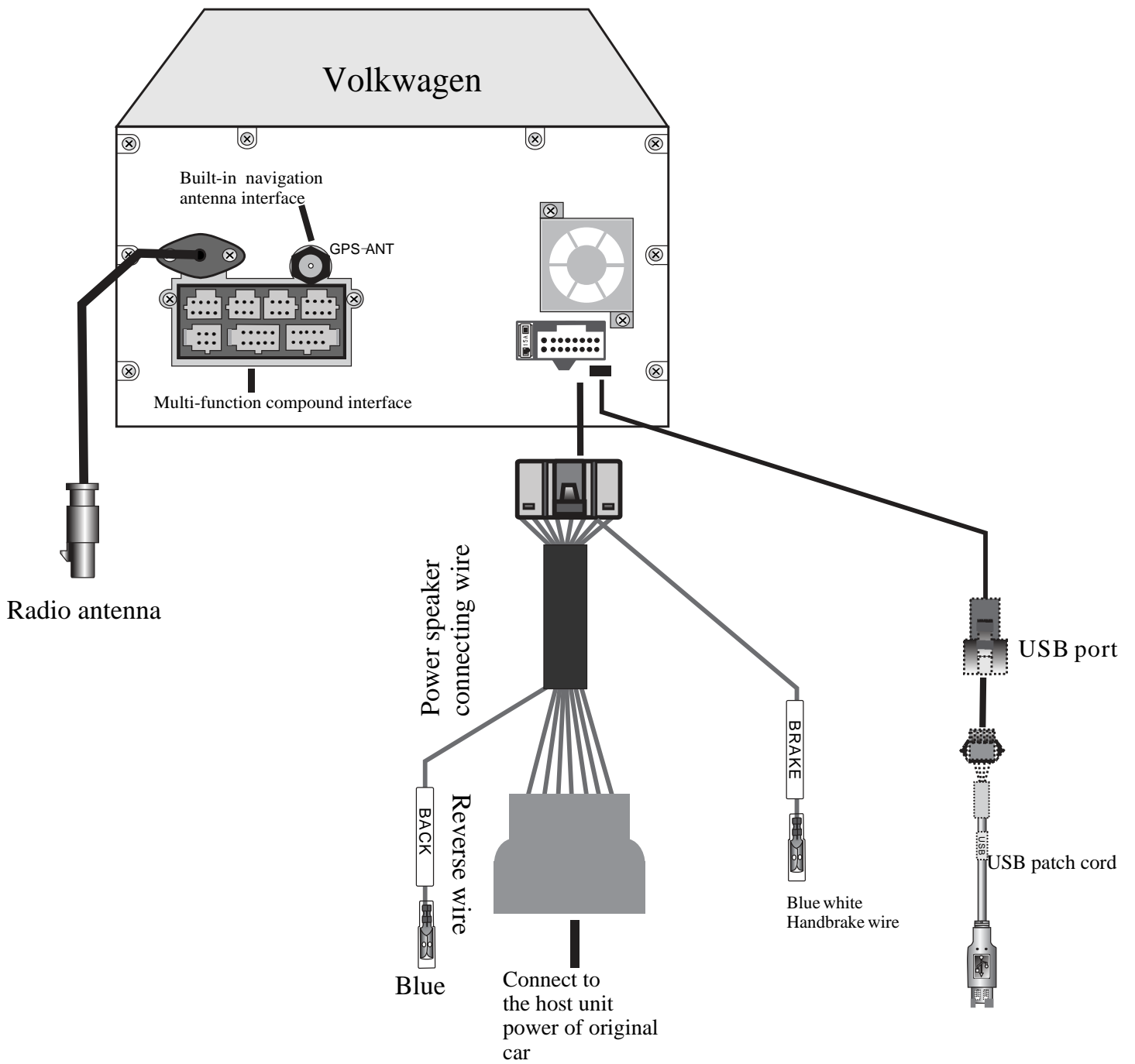

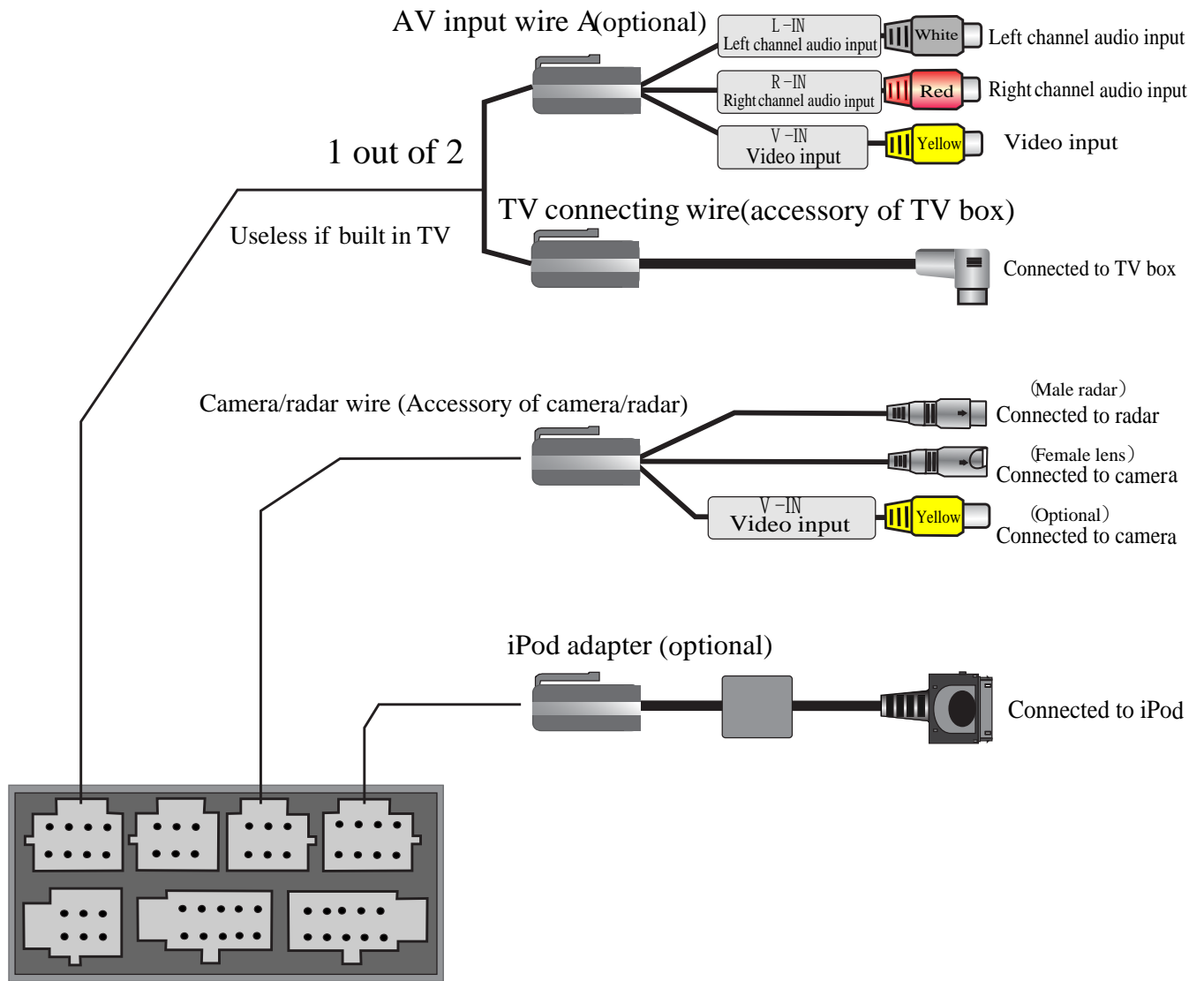

Multi-function compound interface

Multi-function compound interface

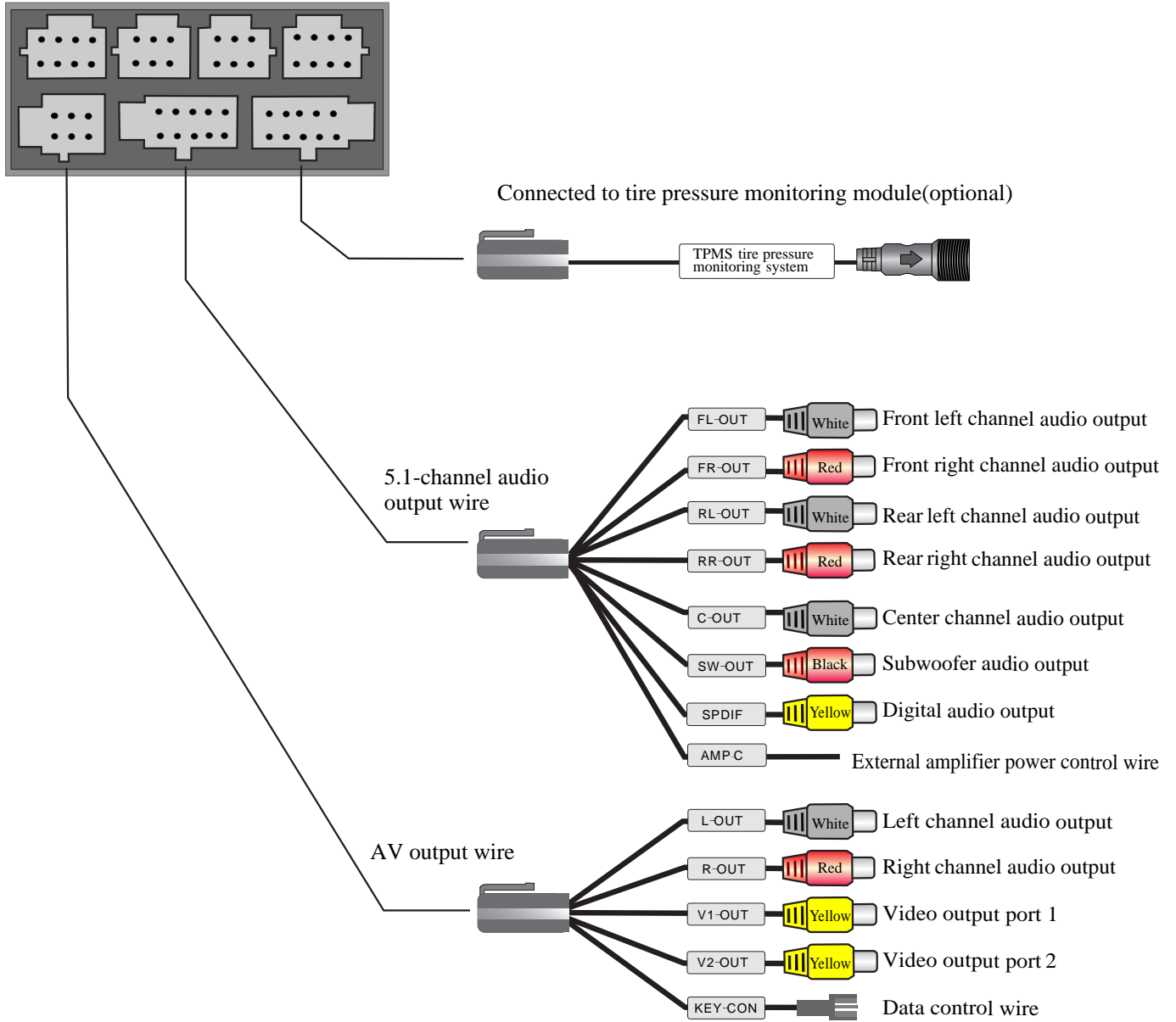



by Johnson Safety Inc.